



**DATE:** November 4, 2024

**MEMO TO:** Paras Parekh, Chair  
Planning Committee

**FROM:** Pati Vitt  
Director of Natural Resources

**RECOMMENDATION:** Recommend approval of a Resolution approving an Intergovernmental Agreement with the Lake County Stormwater Management Commission (SMC) to undertake a Water Quality and Compensatory Storage Project at Rollins Savanna Forest Preserve, funded by SMC in the amount of \$908,739.00 utilizing American Rescue Plan Act Funds.

**STRATEGIC DIRECTIONS SUPPORTED:** Conservation; Organizational Sustainability

**FINANCIAL DATA:** Approving this Agreement will provide the opportunity for the Stormwater Management Commission (SMC) to construct a nature-based stormwater bioretention green infrastructure basin at the downstream end of Mill Creek within the confines of Rollins Savanna Forest Preserve for the purposes of decreasing sedimentation and increasing water quality in Third Lake and to provide compensatory storage for future road work along North Linden Avenue in Avon Township. SMC will fully fund the design, construction, and implementation of this project, and \$908,739.00 in American Rescue Plan Act (ARPA) funds has been allocated and approved for this purpose. As proposed, the District is not required to provide a matching contribution. The proposed compensatory storage will be designed and implemented in a manner that will provide infrastructure to expand the capacity of the Native Seed Nursery to produce emergent wetland plants, an overall benefit to the District.

**BACKGROUND:** In March of 2023, the Village of Third Lake approached the District, and subsequently SMC, to discuss the issue of sediment flowing into Third Lake via Mill Creek – also known as Third Lake Channel Slough and/or the Avon/Fremont Ditch – as it traverses District property north of Washington Street, just adjacent to Linden Lane. SMC and the District agreed that water quality could be improved by in-stream restoration efforts along Mill Creek. Further, SMC had identified a future need for compensatory storage in the same project area for planned roadway upgrades along North Linden Avenue.

With agreement from District staff, SMC retained the services of Hey & Associates to perform an engineering study to provide bank stabilization and in-stream features to reduce sedimentation, and to implement a “scrape” in a portion of the existing cattail monoculture on the east side of Linden Avenue to provide the necessary compensatory storage. District staff proposed that the concept of the scraped area be expanded from depressional water storage to an enhanced wetland plant production area as well as creation of hemi-marsh to support migratory bird populations. The project design includes these elements, as well as protective fencing for the wetland plant production area and a gravel access area, and the District will have the right to review and approve the final project plans prior to construction. On August 2, 2024, the F&A Special Committee on COVID-19 Pandemic Recovery and Investment of the Lake County Board approved ARPA funds in the amount of \$908,739.00 to implement this project.

**REVIEW BY OTHERS:** Director of Finance, Chief Operations Officer, Manager of Board Operations, and Corporate Counsel.



**LAKE COUNTY FOREST PRESERVE DISTRICT  
LAKE COUNTY, ILLINOIS**

**A RESOLUTION APPROVING AN INTERGOVERNMENTAL AGREEMENT WITH  
THE LAKE COUNTY STORMWATER MANAGEMENT COMMISSION FOR  
A WATER QUALITY AND COMPENSATORY STORAGE PROJECT AT  
ROLLINS SAVANNA FOREST PRESERVE**

**WHEREAS**, under Article 7, Section 10 of the Constitution of the State of Illinois, units of local government, such as the Lake County Stormwater Management Commission (the “SMC”) and the Lake County Forest Preserve District (the “District”) are authorized to contract or otherwise associate among themselves, to obtain or share services and to exercise, combine, or transfer any power or function, in any manner not prohibited by law; and

**WHEREAS**, under the Intergovernmental Cooperation Act, 5 ILCS 220/1 *et seq.*, public agencies, such as the SMC and the District, may enter into intergovernmental agreements to exercise, combine, transfer, and enjoy jointly their powers, privileges, functions, or authority in any manner not prohibited by law; and

**WHEREAS**, the SMC and the District jointly desire to improve water quality, restore District lands, and provide compensatory stormwater storage; and

**WHEREAS**, it is in the best interests of the District to enter into an intergovernmental agreement with the SMC, in substantially the form attached hereto, (the "Intergovernmental Agreement") under which (i) the SMC will complete design, construction, and implementation of nature-based stormwater bioretention green infrastructure basins at the downstream end of Mill Creek within the Rollins Savanna Forest Preserve (the “Project”), and (ii) the Project will be fully funded by SMC utilizing American Rescue Plan Act (ARPA) funds that have been allocated and approved for such purposes; and

**WHEREAS**, the Project will be completed in cooperation with the District and in compliance with District restoration standards, will decrease sedimentation and improve water quality within Third Lake, and will increase the capacity of the District to propagate emergent wetland plants for use in its many wetland restoration projects; and

**NOW, THEREFORE, BE IT RESOLVED** by the Board of Commissioners of the Lake County Forest Preserve District, Lake County, Illinois **THAT**:

**Section 1. Recitals.** The recitals set forth above are incorporated as a part of this Resolution by this reference.

**Section 2. Approval of Intergovernmental Agreement.** The Intergovernmental Agreement is hereby approved in substantially the form attached hereto.

**Section 3: Execution of Agreement.** The President and Secretary of the District are authorized to execute and attest to the Intergovernmental Agreement in substantially the form attached hereto.

**Section 4. Effective Date.** This Resolution shall be in full force and effect from and after its passage and approval in the manner provided by law.

PASSED this \_\_\_\_\_ day of \_\_\_\_\_, 2024

AYES:

NAYS:

APPROVED this \_\_\_\_\_ day of \_\_\_\_\_, 2024

\_\_\_\_\_  
Angelo D. Kyle, President  
Lake County Forest Preserve District

ATTEST:

\_\_\_\_\_  
Julie Gragnani, Secretary  
Lake County Forest Preserve District

Exhibit No. \_\_\_\_\_

**INTERGOVERNMENTAL AGREEMENT BETWEEN THE LAKE COUNTY STORMWATER  
MANAGEMENT COMMISSION AND THE LAKE COUNTY FOREST PRESERVE DISTRICT  
FOR WATER QUALITY ENHANCEMENT AND COMPENSATORY STORAGE AT ROLLINS  
SAVANNA FOREST PRESERVE**

**THIS INTERGOVERNMENTAL AGREEMENT** (hereinafter the “Agreement”) is entered into as of \_\_\_\_\_, 2024 by and between the Lake County Stormwater Management Commission, a unit of local government and body politic existing under the laws of the State of Illinois, (hereinafter “SMC”) and the Lake County Forest Preserve District, a body politic and corporate organized and existing under the Downstate Forest Preserve District Act, 70 ILCS 805/0/001 et seq. (hereinafter “LCFPD”) (collectively the “Parties”).

**RECITALS**

**WHEREAS**, Section 10 of Article VII of the Illinois Constitution of 1970 and the Illinois Intergovernmental Cooperation Act, 5 ILCS 220/1 et seq., enable the Parties to enter into agreements among themselves and provide authority for intergovernmental cooperation; and

**WHEREAS**, LCFPD owns and maintains certain property commonly known as the Rollins Savanna Forest Preserve, which is generally depicted in Exhibit A (the “Property”), which includes portions of Third Lake and Mill Creek; and

**WHEREAS**, the Parties jointly desire to undertake a project to improve water quality, reduce sedimentation in Third Lake, improve stormwater management through compensatory storage, and restore wetlands by in-stream restoration efforts along Mill Creek, which project will specifically include implementing nature-based stormwater bioretention green infrastructure basins (wetland scrapes) along portions of Mill Creek within the Property (the “Mill Creek Water Quality Enhancement Project” or “Project”), all as more specifically depicted in the plans attached as Exhibit C (the “Plans”); and

**WHEREAS**, SMC has allocated, and the Special Committee on Covid-19 Pandemic Recovery and Investment of the Lake County Board has approved, \$908,739.00 in funds available under the American Rescue Plan Act (“ARPA”) to design, construct, and implement the Project; and

**WHEREAS**, the Parties agree that SMC shall be the responsible entity to design, bid, manage, and implement the Project in accordance with this Agreement, and for such purposes LCFPD will grant SMC a license, as provided herein, over the approximately 85-acre portion of the Property generally depicted on Exhibit B (the “Licensed Premises”); and

**WHEREAS**, the Parties agree that LCFPD shall have no obligation to fund the design, construction, or implementation of the Project, but LCFPD shall have the right to final approval of the Project design in accordance with this Agreement and shall be responsible to maintain, improve, and repair the Project after its completion by SMC, all as further set forth herein; and

**WHEREAS**, the Parties desire to enter into this Agreement to set forth their respective rights and responsibilities in relation to the Project, and the Parties agree that the Project will

provide a public benefit by improving water quality, reducing sedimentation into Third Lake, restoring wetlands, and providing compensatory storage to improve stormwater management;

**NOW THEREFORE**, in consideration of the matters set forth, the mutual covenants and agreements contained in this agreement and other good and valuable consideration, SMC and LCFPD hereby agree as follows:

**Article 1. Incorporation of Recitals.**

The recitals set forth above are incorporated herein by reference and made a part hereof.

**Article 2. Scope of Work; Project Design and Implementation.**

1. SMC shall cause to be prepared construction drawings, specifications, and details (hereinafter the "Construction Documents") for the Project that are consistent with the Plans. The parties acknowledge that SMC has retained Hey & Associates to provide engineering, design, and consultant services, as well as assist with the bidding and permitting process and construction management for the Project.
2. The Parties agree that the Project will establish nature-based stormwater bioretention green infrastructure that will consist of the construction of restoration features for the purpose of habitat restoration, water quality improvement, and flood mitigation as generally depicted on the Plans and to be more specifically detailed in the Construction Documents. Specific features include wetland scrapes, bank stabilization, and in-stream habitat features as well as site access and restoration along downstream portions of Mill Creek within the Licensed Premises.
3. Before undertaking any work on the Licensed Premises, SMC shall provide LCFPD with a copy of the complete Construction Documents for LCFPD's review, comment, and approval. LCFPD shall review and provide comments or approval to SMC in writing within 14 days of receipt of the complete Construction Documents. The Construction Documents shall include invasive species mitigation and control measures as reasonably specified by LCFPD.
4. SMC, at its sole cost and expense, shall bid, manage, construct, and implement the Project in accordance with the final Construction Documents and all applicable laws.
5. SMC, at its sole cost and expense, shall monitor and maintain all Project improvements within the Licensed Premises until the later of (i) December 31, 2026 or (ii) completion of the Project construction and implementation, including expending all contracted herbicide task hours (the "Expiration Date").
6. LCFPD, at its sole cost and expense, shall have the responsibility to monitor and maintain all Project improvements after the Expiration Date.
7. SMC and LCFPD shall cooperate to determine mutually acceptable performance monitoring and reporting standards for the Project.

**Article 3. Work.**

1. SMC, its contractors, and any of its third-party agents, shall construct all Project improvements and complete all work on the Licensed Premises (the "Work"), in a good and workmanlike manner, at no cost to LCFPD, in accordance with this Agreement and all applicable laws. Without limiting the preceding sentence, SMC, at no cost to LCFPD, shall perform any required maintenance and monitoring Work until the Expiration Date, at which point LCFPD shall assume all future management and maintenance obligations.
2. SMC may cause any portion of the Work to be performed by a contractor (a "Work Contractor") but only if and after (i) SMC has entered into a written contract with such Work Contractor (a "Work Contract") in which the Work Contractor agrees to comply with all of SMC's obligations under Articles 3 (Work), 5 (Licensed Premises Restrictions), 13 (Insurance and Liens), 15 (Indemnification), 24 (Notices), and 25 (Termination) of this Agreement, and (ii) LCFPD has first had an opportunity to review the Work Contract. Even if SMC enters into a Work Contract, SMC is not relieved of its obligation to perform the Work in accordance with, and to otherwise comply with, this Agreement.

#### **Article 4. License.**

1. LCFPD hereby grants to SMC a license (the "License") to use the Licensed Premises for the purpose of designing, constructing, managing, and implementing the Project in accordance with this Agreement. The License shall include reasonable rights of ingress and egress to the Licensed Premises from a public roadway in location(s) specified by LCFPD.
2. SMC acknowledges that (i) the Licensed Premises are, and will remain at all times, the property of LCFPD, (ii) this Agreement grants contractual license rights only and does not create an easement, a leasehold, or any other real property rights, and (iii) LCFPD shall retain legal possession and control over the Licensed Premises. LCFPD represents that its purposes in entering into this Agreement are as set forth in this Agreement, and that this Agreement provides for intergovernmental cooperation for the completion of the Project on the Licensed Premise for the benefit of the public and for the furtherance of LCFPD's statutory mission, all of which is reasonably related to the purposes for which LCFPD was created. Therefore, the Parties agree that this agreement grants a license pursuant to Section 7b of the Downstate Forest Preserve District Act, 70 ILCS 805/7b.

#### **Article 5. Licensed Premises Restrictions.**

Any activity in or use of the Licensed Premises by SMC that is inconsistent with this Agreement is prohibited. Without limiting the generality of the foregoing, the following activities and uses are expressly prohibited in, on, over, or under the Licensed Premises:

1. Structures. Except for the construction of Project improvements in conformity with the approved Construction Documents, the construction of other man-made structures including, but not limited to, the construction, removal, placement, preservation, maintenance or alteration of any buildings, roads, utility lines, billboards, or other advertising.

2. Demolition. Except as expressly provided in the Construction Documents, the demolition or removal of existing structures, fences, or other improvements, if any, within the Licensed Premises.
3. Waste or Debris. The storage, dumping, depositing, abandoning, discharging, or releasing of any gaseous, liquid, solid, or hazardous waste substance, materials or debris of whatever nature on, in, over, or underground or into surface or ground water.
4. Restricted Public Access. Interference with public access to the Property, except that during construction of the Project, LCFPD and SMC shall cooperate as needed to limit or prohibit general public access to construction areas and/or areas designated as sensitive areas.
5. Removal of Vegetation. The mowing, cutting, pruning, removal, disturbance, destruction, or collection of any trees, shrubs, or other vegetation, except in accordance with the Construction Documents or as otherwise approved by the District for:
  - a. safety;
  - b. control in accordance with accepted scientific forestry management practices for diseased or dead vegetation;
  - c. control of non-native species and noxious weeds; or
  - d. scientific nature study.
6. Other. Other acts, uses, excavation, or discharges, which adversely affect fish or wildlife habitat or the preservation of lands, waterways, or other natural resources located within the Licensed Premises.

#### **Article 6. Reserved Rights.**

1. This Agreement will not prevent LCFPD from using the Property or the Licensed Premises in any manner that is not inconsistent with this Agreement.
3. This Agreement will not prevent LCFPD from undertaking any future necessary or desired maintenance, repair, or enhancements to the Licensed Premises.

#### **Article 7. Permits and Fees.**

SMC, or its agent or designee, shall obtain all federal, state, and County permits, consents, and approvals, if any, required by law for the construction of the Project and shall assume any and all costs incurred in procuring such permits, consents, and approvals.

#### **Article 8. Ownership.**

1. Upon completion of the Project, LCFPD will own all Project improvements constructed or installed upon the Licensed Premises.

2. Nothing in this Agreement shall be construed as granting SMC any real property interest or ownership interest over the Project improvements, the Licensed Premises, or the Property.

**Article 9. Schedule of Construction.**

SMC shall put the Project out for bid in 2024, begin construction of the Project in 2025, and complete all Work by December 31, 2026. The Construction Documents to be prepared and submitted by SMC for LCFPD's review and approval shall include a detailed construction schedule for the Project.

**Article 10. Effective Date.**

This Agreement shall be effective as of the date that the latest date set forth on the signature pages affixed hereto.

**Article 11. Non-Assignment.**

No party may assign its rights or obligations hereunder without the written consent of the other party.

**Article 12. Waiver of Personal Liability.**

No official, employee, or agent of any party to this Agreement shall be charged personally by the other party with any liability or expenses of defense incurred as a result of the exercise of any rights, privileges, or authority granted herein, nor shall he or she be held personally liable under any term or provision of this Agreement, or because of a party's execution or attempted execution of this Agreement, or because of any breach of this Agreement.

**Article 13. Insurance and Liens.**

1. SMC shall procure and maintain, at all times until the Expiration Date or during which SMC is present on the Licensed Premises, at SMC's sole cost and expense, commercial general liability insurance naming LCFPD as an additional insured with combined limits of not less than \$1,000,000.00 per occurrence for bodily injury (including death) and property damage, and \$2,000,000.00 aggregate (Umbrella/Excess coverage can be used in combination with primary general liability to satisfy this requirement), and shall furnish evidence of such insurance coverage by way of certificates of insurance which shall provide for thirty (30) days' notice of cancellation. All policies shall provide a waiver of subrogation in favor of LCFPD and its affiliates. SMC shall require its Work Contractors and its agents, engineers, representatives, and contractors performing any work or services upon the Licensed Premises to procure and maintain commercial general liability insurance in commercially reasonable amounts (not to exceed the amounts set forth hereinabove) until completion of their respective work or services, naming LCFPD and its affiliates and SMC, respectively, as additional insureds and complying with all other requirements of this provision. Certificates of such insurance, in form reasonably satisfactory to LCFPD, shall be delivered to SMC and forwarded by SMC to LCFPD.

2. In exercising its rights under this Agreement, SMC shall comply with all applicable laws and shall not permit any liens to attach to the Licensed Premises. Should any such liens be filed against or attach to the Licensed Premises, SMC shall cause them to be removed of record and fully discharged at SMC's sole cost and expense within ten (10) days following notice thereof to SMC.

#### **Articles 14. Damages to LCFPD property.**

The Work shall be confined entirely to the Licensed Premises. If the Property or any other property of LCFPD is damaged by SMC, its Work Contractors, or any other of SMC's agents, engineers, representatives, and contractors, then SMC shall repair and restore the damaged property to its condition prior to such damage. The Parties acknowledge that reasonable and normal wear, tear, and erosion do not constitute "damage".

#### **Article 15. Indemnification.**

1. SMC shall defend, indemnify, and hold harmless LCFPD and its commissioners, officers, engineers, attorneys and other agents (hereinafter a "LCFPD Indemnified Party") from liabilities of every kind, including losses, damages and reasonable costs, payments and expenses (such as, but not limited to, court costs and reasonable attorneys' fees and disbursements), claims, demands, actions, suits, proceedings, judgments or settlements, any or all of which are asserted by any individual, private entity, or public entity against any LCFPD Indemnified Party and arise out of or are in any way related to: (1) SMC's performance or exercise of any of its obligations, rights, privileges, or authority under this Agreement, or (2) SMC's design, management, or construction of the Project.
2. LCFPD shall defend, indemnify, and hold harmless SMC and its commissioners, officers, engineers, attorneys and other agents (hereinafter a "SMC Indemnified Party") from liabilities of every kind, including losses, damages and reasonable costs, payments and expenses (such as, but not limited to, court costs and reasonable attorneys' fees and disbursements), claims, demands, actions, suits, proceedings, judgments or settlements, any or all of which are asserted by any individual, private entity, or public entity against any SMC Indemnified Party and arise out of or are in any way related to LCFPD's performance or exercise of any of its obligations, rights, privileges, or authority under this Agreement.

#### **Article 16. Disclaimers.**

This Agreement is not intended, nor shall it be construed, to confer any rights, privileges, or authority not permitted by Illinois law. Nothing in this Agreement shall be construed to establish a contractual relationship between any of the Parties and any third party not otherwise a party to this Agreement.

#### **Article 17. Waivers.**

Whenever a party to this Agreement by proper authority waives the other party's performance in any respect or waives a requirement or condition to performance, the waiver so granted, whether express or implied, shall only apply to the particular instance and shall not be deemed a waiver

for subsequent instances of the performance, requirement, or condition. No such waiver shall be construed as a modification of this Agreement regardless of the number of times the performance, requirement, or condition may have been waived.

**Article 18. Severability.**

If any provision of this Agreement is held to be invalid, illegal, or unenforceable, such invalidity, illegality, or unenforceability will not affect any other provisions of this Agreement, and this Agreement will be construed as if such invalid, illegal, or unenforceable provision has never been contained herein. The remaining provisions will remain in full force and will not be affected by the invalid, illegal, or unenforceable provision or by its severance. In lieu of such illegal, invalid, or unenforceable provision, there will be added automatically as part of this Agreement a provision as similar in its terms to such illegal, invalid, or unenforceable provision as may be possible and be legal, valid, and enforceable.

**Article 19. Necessary Documents.**

Each party agrees to execute and deliver all further documents and take all further action reasonably necessary to effectuate the purpose of this Agreement.

**Article 20. Deemed Inclusion.**

Any provisions required (as of the effective date) by law, ordinances, rules, regulations, or executive orders to be inserted in this Agreement are deemed inserted in this Agreement whether or not they appear in this Agreement or, upon application by either party, this Agreement will be amended to make the insertions; however, in no event will the failure to insert such provisions before or after this Agreement is signed prevent its enforcement.

**Article 21. Entire Agreement.**

This Agreement, and any exhibits or riders attached hereto, shall constitute the entire agreement between the Parties. No other warranties, inducements, considerations, promises, or interpretations shall be implied or impressed upon this Agreement that are not expressly set forth herein.

**Article 22. Amendments.**

This Agreement shall not be amended unless it is done so in writing and signed by the authorized representatives of each of the Parties.

**Article 23. Judicial and Administrative Remedies.**

The parties agree that this Agreement shall be governed by, and construed and enforced in accordance with, the laws of the State of Illinois, without reference to its choice of law provisions. The parties further agree that the proper venue to resolve any dispute which may arise out of this Agreement is the appropriate Court of competent jurisdiction located in Lake County, Illinois.

**Article 24. Notices.**

All notices required or permitted hereunder shall be in writing, and delivered either personally or by certified or registered mail, return receipt requested, to the following addresses or sent by electronic mail ("e-mail") to the following contact addresses:

If to Lake County Stormwater Management Commission:

Michelle Pope, Project Manager  
Lake County Stormwater Management Commission  
500 W. Winchester Road  
Libertyville, IL 60048  
Phone: 847-377-7700  
Email: [mpope@lakecountyil.gov](mailto:mpope@lakecountyil.gov)

If to Lake County Forest Preserve District:

\_\_\_\_\_  
\_\_\_\_\_  
\_\_\_\_\_  
\_\_\_\_\_  
Phone: \_\_\_\_\_  
Email: \_\_\_\_\_

Each party agrees to promptly notify the other party of any change in its designated representative, which notice shall include the name, address, telephone number and fax number of the representative for such party for the purpose hereof.

**Article 25. Termination.**

Notwithstanding anything herein to the contrary, if SMC intentionally, willfully, or in a grossly negligent manner commits any act or does anything that damages the Licensed Premises or materially and adversely affects its ecological state, then LCFPD may, upon written notice to SMC, immediately terminate this Agreement and pursue any and all remedies available at law or equity, including a suit for damages.

**Article 26. Miscellaneous.**

1. This Agreement may be executed in multiple counterparts. The Parties agree that the electronic signature of a Party to this Agreement shall be as valid as an original signature of such Party and shall be effective to bind such Party to this Agreement.
2. Each Party agrees, and advises the other, to seek their own legal advice with respect to entering into this Agreement, and any particular issue or term related thereto. The Parties hereto acknowledge that the Parties and their counsel have reviewed and revised this Agreement and agree that the normal rule of construction to the effect that any ambiguities are to be resolved against the drafting Party shall not be employed in the interpretation of this Agreement or any exhibits or amendments hereto.
3. Time is of the essence in the performance of this Agreement.

4. If the day for performance of any obligation hereunder, or the last day of a particular time period provided for herein, falls on a Saturday, Sunday, or legal holiday recognized by national banks in Lake County, Illinois, such day for performance, and the expiration of such time period, as the case may be, shall be the next day which is not a Saturday, Sunday or such legal holiday.

*[SIGNATURES ON FOLLOWING PAGE(S)]*

**IN WITNESS WHEREOF**, the Lake County Stormwater Management Commission, and the Lake County Forest Preserve District, the parties hereto, have each caused this Agreement to be executed by their duly authorized officers, on the dates specified below.

**LAKE COUNTY STORMWATER MANAGEMENT COMMISSION:**

\_\_\_\_\_  
Kurt Woolford, Executive Director  
Lake County Stormwater Management Commission

\_\_\_\_\_  
Date

**LAKE COUNTY FOREST PRESERVE DISTRICT:**

\_\_\_\_\_  
Angelo D. Kyle, President  
Lake County Forest Preserve District

\_\_\_\_\_  
Date

Attest: \_\_\_\_\_  
Julie Gagnani, Secretary  
Lake County Forest Preserve District

\_\_\_\_\_  
Date

**EXHIBIT A**  
**DEPICTION OF THE PROPERTY**

**EXHIBIT B**  
**DEPICTION OF THE LICENSED PREMISES**

**EXHIBIT C**  
**MILL CREEK WATER QUALITY ENHANCEMENT**  
**BID PLAN**  
**Hey and Associates, Inc.**

# Mill Creek Water Quality Enhancement Third Lake, IL

**Client:**

Lake County SMC  
500 W. Winchester Road, Suite 201  
Libertyville, Illinois 60048  
(847) 377-7700

**Engineer:**

**Hey and Associates, Inc.**  
26575 West Commerce Drive, Suite 601  
Volo, Illinois 60073  
Office (847) 740-0888  
Fax (847) 740-2888

**Benchmark:**

CP 1: Northeastern shoulder of intersection of  
Linden Avenue and W Washington Street.  
Elevation = 770.480 (NAVD 1988)  
CP 2: High point along the eastern side of Linden  
Avenue. Elevation = 770.608 (NAVD 1988).  
CP 3: Western edge of asphalt along Linden  
Avenue across from northern access trail.  
Elevation = 772.377 (NAVD 1988).  
As established by GPS observations 08/24/2024.

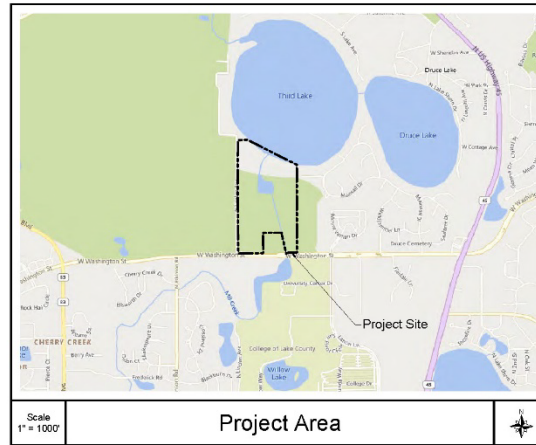

**Sheet Index:** (Page # / Sheet # / Title)

1. C1.0 Cover Sheet
2. C1.1 General Notes and Legend
3. C1.2 Existing Conditions
4. C2.0 Overall Plan
5. C2.1 Plan Enlargement
6. C2.2 Plan Enlargement
7. C2.3 Plan Enlargement
8. C3.0 Soil Erosion and Sediment Control Plan
9. C4.0 Restoration Plan
10. C5.0 Details
11. C5.1 Details
12. C5.2 Details

Call J.L.L.E. 1-800-962-0123 at least 48 hours  
before start of construction with the following:  
County: Lake  
City or Township: Averb Township  
Tax Range & Section: T43N, R18E, Sec. 34

The information shown on this drawing concerning type and  
location of underground utilities is not guaranteed to be  
accurate or complete. The Contractor is responsible for  
making his own determination as to the type and location  
of underground utilities as may be necessary to avoid  
damage thereto.

PROFESSIONAL SEAL



Signature: *[Signature]*  
Date: 10/07/2024  
License Expires: 11/30/2025

This document shall not be considered a valid technical  
document unless I draw an original seal and signature.

Base Survey Information provided by:  
Lake County Stormwater Management  
Commission, Lake County LIDAR,  
Hey and Associates, Inc.

No.	Revised Issues	Date

**Hey and Associates, Inc.**  
Engineering, Surveying and Landscape Architecture  
26575 WEST COMMERCE DRIVE, SUITE 601  
VOLO, ILLINOIS 60073  
OFFICE (847) 740-0888  
FAX (847) 740-2888  
VOLON@HEYASSOC.COM  
PROFESSIONAL DESIGN FIRM  
LICENSED NO. 184-002429

Mill Creek Water Quality  
Enhancement  
Lake County, IL

Cover Sheet

PROJECT NO.	DATE	ISSUE NO.
24-0250	10/07/24	1

Issued for Bid



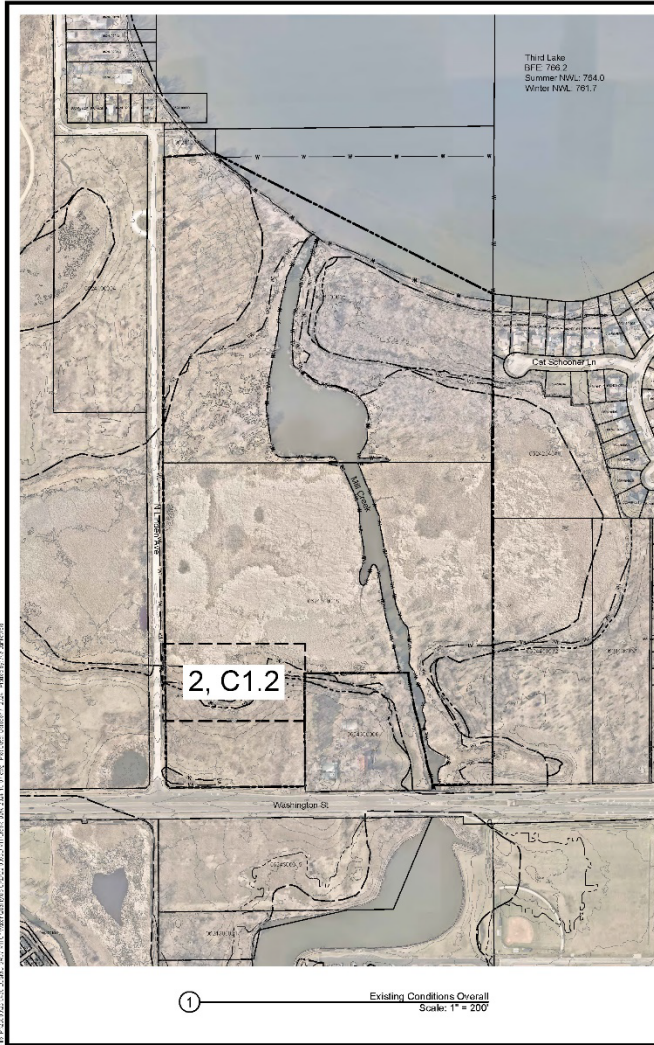

ID	SCIENTIFIC NAME	COMMON NAME	DBH (in)
1	<i>Prunus serotina</i>	Black Cherry	5
2	<i>Celtis occidentalis</i>	Hackberry	8
3	<i>Prunus serotina</i>	Black Cherry	28
4	<i>Prunus serotina</i>	Black Cherry	17
5	<i>Ulmus americana</i>	American Elm	35
6	<i>Populus deltoides</i>	Eastern Cottonwood	25
7	<i>Populus deltoides</i>	Eastern Cottonwood	19
8	<i>Populus deltoides</i>	Eastern Cottonwood	29
9	<i>Populus deltoides</i>	Eastern Cottonwood	26
10	<i>Populus deltoides</i>	Eastern Cottonwood	22
11	<i>Acer spicatum</i>	Silver Maple	17
12	<i>Acer spicatum</i>	Silver Maple	7
13	<i>Populus deltoides</i>	Eastern Cottonwood	23
14	<i>Populus deltoides</i>	Eastern Cottonwood	33
15	<i>Populus deltoides</i>	Eastern Cottonwood	46
16	<i>Acer spicatum</i>	Silver Maple	24
17	<i>Acer spicatum</i>	Silver Maple	17
18	<i>Prunus serotina</i>	Black Cherry	6
19	<i>Prunus serotina</i>	Black Cherry	22
20	<i>Prunus serotina</i>	Black Cherry	14
21	<i>Prunus serotina</i>	Black Cherry	23
22	<i>Prunus serotina</i>	Black Cherry	11
23	<i>Acer spicatum</i>	Silver Maple	13
24	<i>Prunus serotina</i>	Black Cherry	16
25	<i>Prunus serotina</i>	Black Cherry	16
26	<i>Prunus serotina</i>	Black Cherry	6
27	<i>Prunus serotina</i>	Black Cherry	9
28	<i>Prunus serotina</i>	Black Cherry	9
29	<i>Acer spicatum</i>	Silver Maple	24
30	<i>Acer spicatum</i>	Silver Maple	8
31	<i>Prunus serotina</i>	Black Cherry	7
32	<i>Prunus serotina</i>	Black Cherry	10
33	<i>Prunus serotina</i>	Black Cherry	6
34	<i>Prunus serotina</i>	Black Cherry	6
35	<i>Prunus serotina</i>	Black Cherry	11
36	<i>Prunus serotina</i>	Black Cherry	25
37	<i>Prunus serotina</i>	Black Cherry	11
38	<i>Prunus serotina</i>	Black Cherry	8
39	<i>Prunus serotina</i>	Black Cherry	8
40	<i>Prunus serotina</i>	Black Cherry	10
41	<i>Prunus serotina</i>	Black Cherry	6
42	<i>Prunus serotina</i>	Black Cherry	8
43	<i>Prunus serotina</i>	Black Cherry	6
44	<i>Prunus serotina</i>	Black Cherry	8

0 200 400  
Scale in Feet

**LEGEND**

- Project Boundary
- Parcel Boundary
- FEMA Floodplain - by Elevation
- FEMA Floodway
- Lake County Contours
- Surveyed Wetland Boundary
- Surveyed Waters Boundary
- Control Point
- Existing Deciduous Tree

No.	Revision/Issue	Date

**Hey and Associates, Inc.**  
Engineering, Ecology and Landscape Architecture  
26575 WEST COMMERCE DRIVE, SUITE 601  
VOLA, ILLINOIS 60073  
OFFICE (847) 740-0888  
FAX (847) 740-2888  
VOL@HYASOC.COM  
PROFESSIONAL DESIGN FIRM  
LICENSE NO. 184-002429

**Mill Creek Water Quality  
Enhancement**  
Lake County, IL

**Existing Conditions**

PROJECT NO.	28-0430	SHEET NO.	C1.2
DRAWN BY	DAK	CHECKED BY	ATJ/REB
DESIGNED BY	DAK	APPROVED BY	
DATE	10/27/2024	SCALE	AS SHOWN

**Issued for Bid**





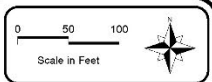
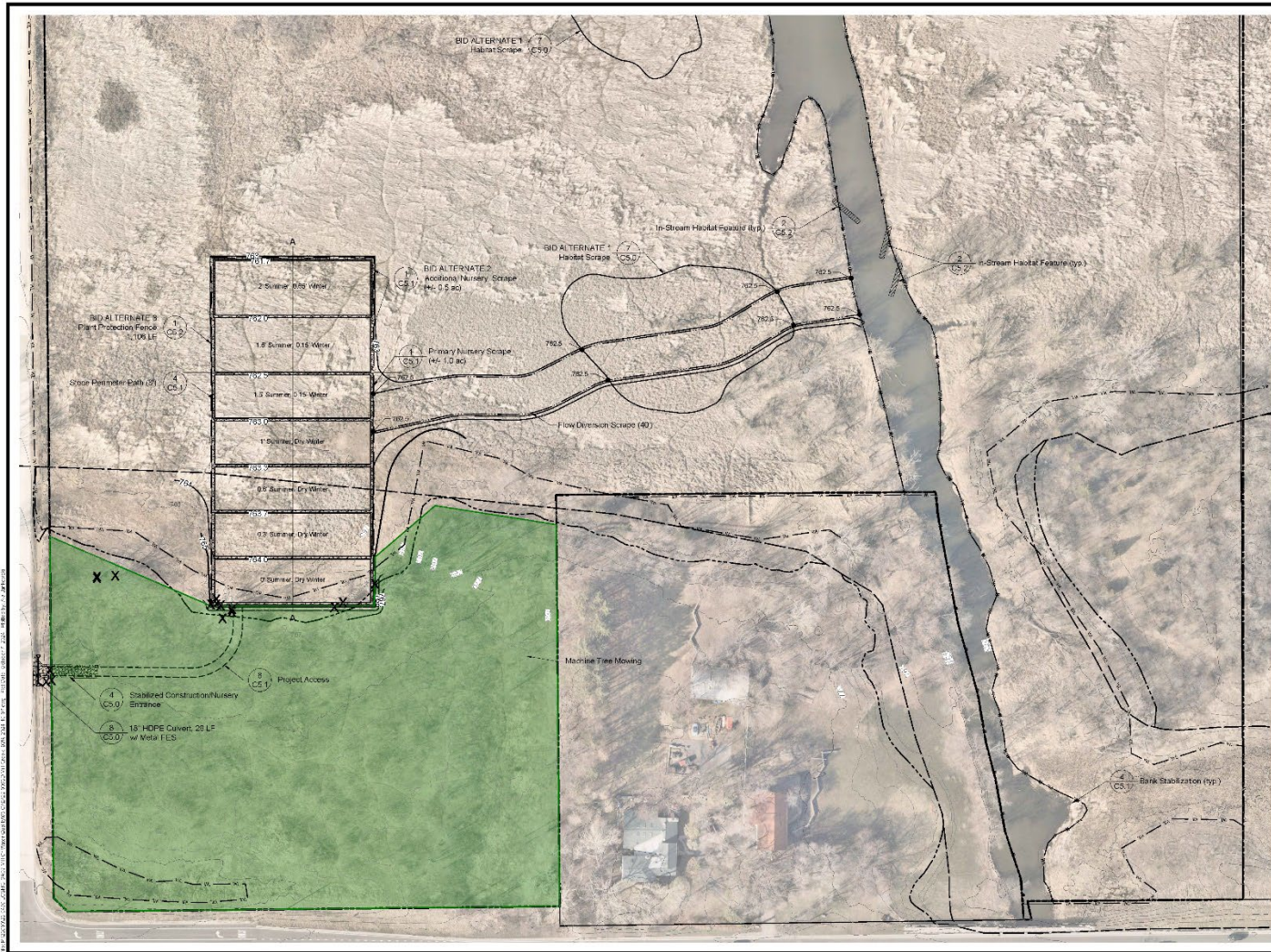

**LEGEND**

- Project Boundary
- Parcel Boundary
- FEMA Floodplain by Elevation
- FEMA Floodway
- Lake County Contours
- Surveyed Wetland Boundary
- Surveyed Waters Boundary
- Prop. Contours
- Prop. Construction/Nursery Access Edge
- Prop. Flow Diversion
- Prop. Plant Protection Fence
- Prop. Stone Perimeter Path
- Prop. In-Stream Habitat Feature
- Prop. Bank Stabilization
- Machine Tree Mowing
- Existing Deciduous Tree
- Pr. Tree Removal

No.	Revision/Issue	Date

**Hey and Associates, Inc.**  
 Engineering, Ecology and Landscape Architecture  
 26575 West Cawood Circle, Suite 801  
 Villa, Illinois 60073  
 Office: (847) 740-0888  
 Fax: (847) 740-2888  
 info@heyassoc.com

PROFESSIONAL DESIGN FIRM  
 LICENSE NO. 184-002629

Mill Creek Water Quality  
 Enhancement  
 Lake County, IL

South Area Plan

PROJECT NO.	DATE	SHEET NO.
16517-00001	05-04-20	0487-05
DESIGNED BY	DAK	C2.2
CHECKED BY	AT/BEG	
DRAWN BY	JAW	NOTED BY
ISSUED BY	DAK	DATE
ISSUE NO.	100272024	8 OF 12

Issued for Bid



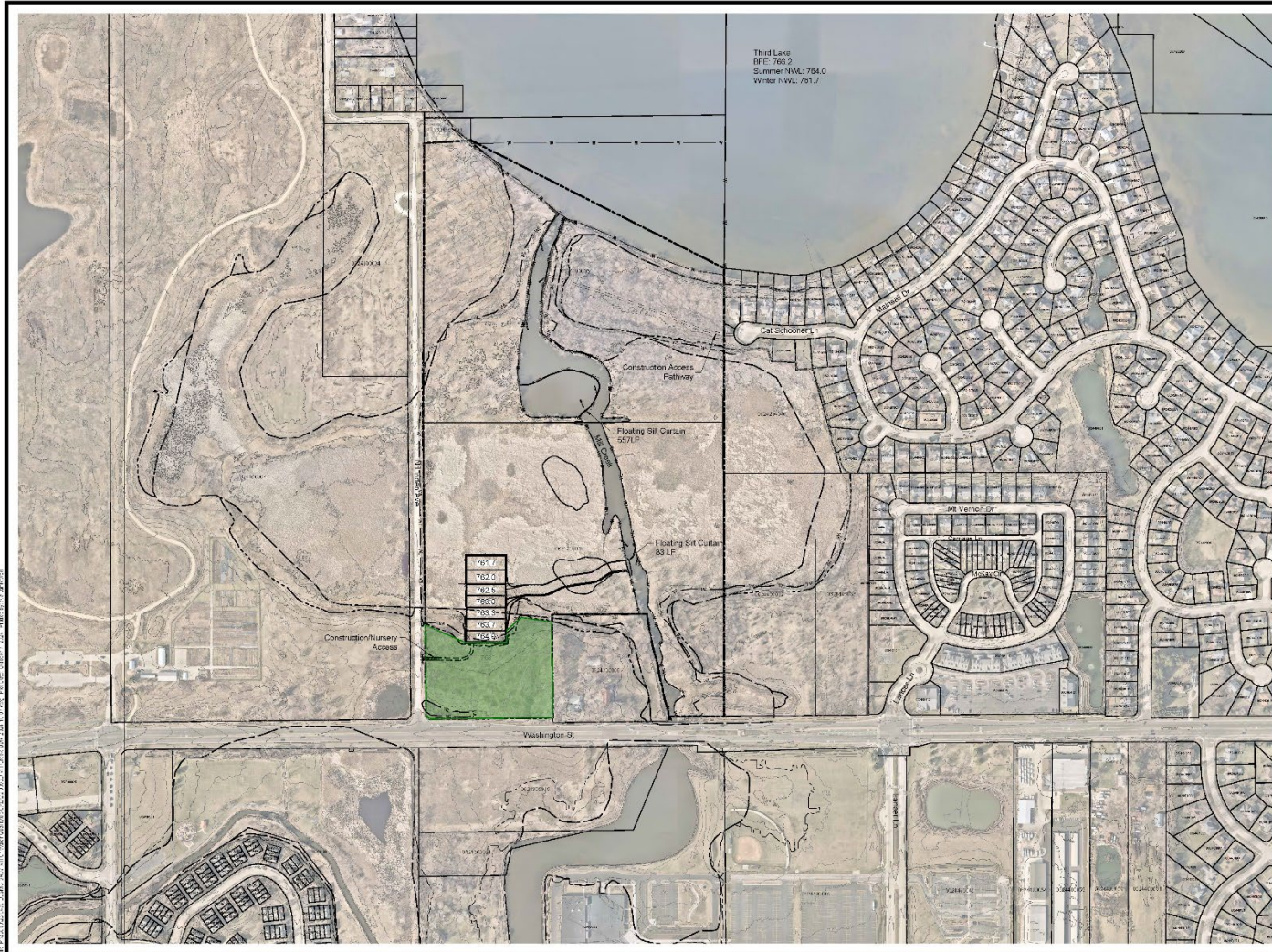

Third Lake  
 DFE: 765.9  
 Summer NML: 764.0  
 Winter NWL: 761.7

767.71
767.0
767.5
768.0
768.5
768.7
768.9



**LEGEND**

- Project Boundary
- Parcel Boundary
- FEMA Floodplain by Elevation
- FEMA Floodway
- Lake County Contours
- Surveyed Wetland Boundary
- Surveyed Waters Boundary
- Prop. Contours
- Prop. Construction/Nursery Access Edge
- Prop. Flow Diversion
- Prop. Floating Silt Curtain
- Prop. Temp. Construction Access Path

No. \_\_\_\_\_ Revision \_\_\_\_\_ Date \_\_\_\_\_

**Hey and Associates, Inc.**  
 Engineering, Ecology and Landscape Architecture  
 26575 WEST COMMERCIAL DRIVE, SUITE 601  
 Volo, Illinois 60073  
 OFFICE (847) 740-6888  
 FAX (847) 740-2888  
 VOLO@HAYASOC.COM  
 PROFESSIONAL DESIGN FIRM  
 LICENSE NO. 184-02429

**Mill Creek Water Quality Enhancement**  
 Lake County, IL

**Soil Erosion and Sediment Control Plan**

PROJECT NO.	28-0430	SHEET NO.	
DRAWN BY	DAK	CHECKED BY	C3.0
DATE	AT/08/08		
CHECKED BY	JAN	DATE	
APPROVED BY	DAK	REVISION	
SCALE	1:607/2624	SHEET	12

Issued for Bid

DATE PLOTTED: 08/11/08 10:57 AM USER: DAK



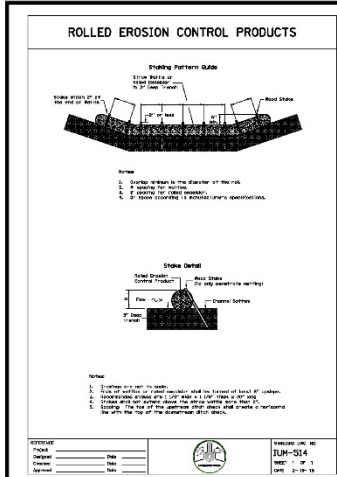

1 Perimeter Erosion Barrier Detail (Not to Scale)

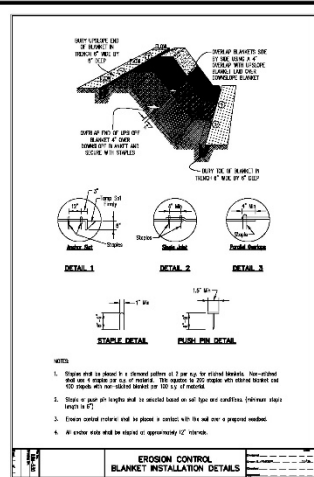

2 Erosion Control Blanket Detail (Not to Scale)

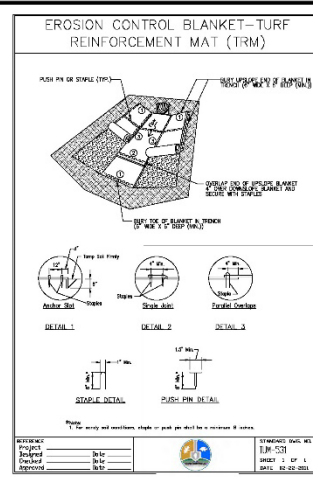

3 Turf Reinforcement Mat Detail (Not to Scale)

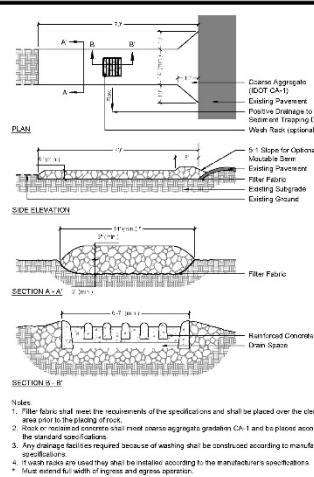

4 Stabilized Construction Entrance Detail (Not to Scale)

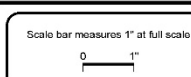

LEGEND

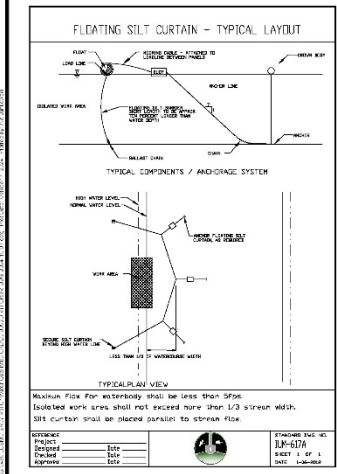

5 Floating Silt Curtain - Layout Detail (Not to Scale)

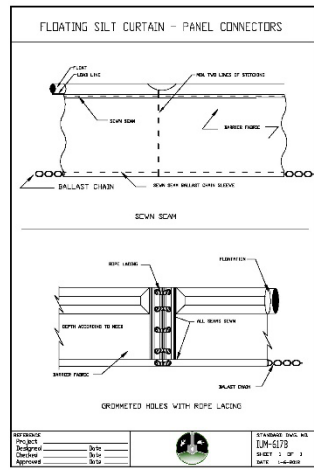

6 Floating Silt Curtain - Connection Detail (Not to Scale)

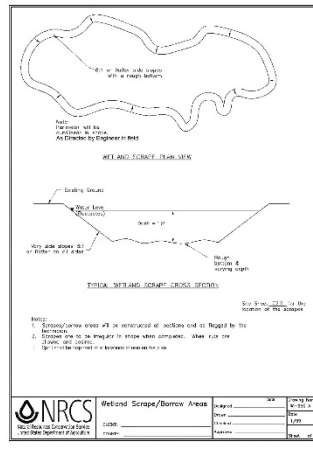

7 BID-AI TRFNATE 1 Habitat Scrape Detail (Not to Scale)

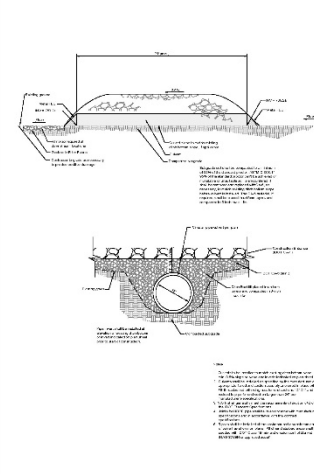

8 Access Path Culvert (Not to Scale)

No.	Revision/Issue	Date
-----	----------------	------

**Hey and Associates, Inc.**  
Engineering, Surveying and Landscape Architecture  
26575 WEST COMBACH DRIVE, SUITE 601  
VOLO, ILLINOIS 60073  
OFFICE (847) 740-8888  
FAX (847) 740-2888  
VOLO@HEYASSOC.COM  
PROFESSIONAL DESIGN FIRM  
LICENSE NO. 184-02420

Mill Creek Water Quality Enhancement  
Lake County, IL

Details

PROJECT NO.	23-0430	SHEET NO.	
DRAWN BY	DKR	CHECKED BY	ATJ/REB
DATE PLOTTED	JAN 11 2011	SCALE	C5.0
DATE REVISION		DATE	
DATE PLOTTED	10/07/2024	SCALE	10" = 12'

Issued for Bid

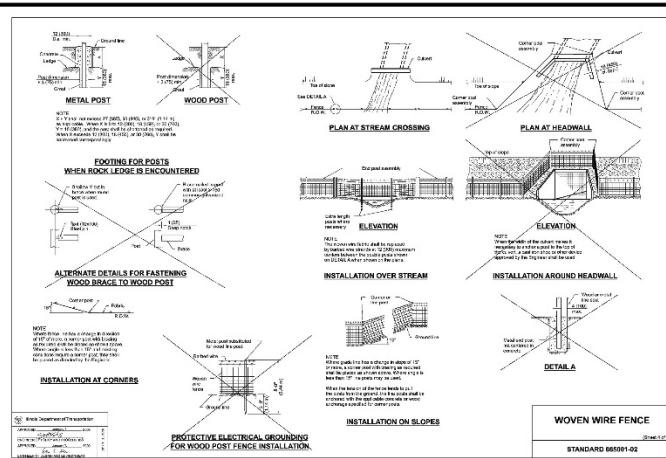
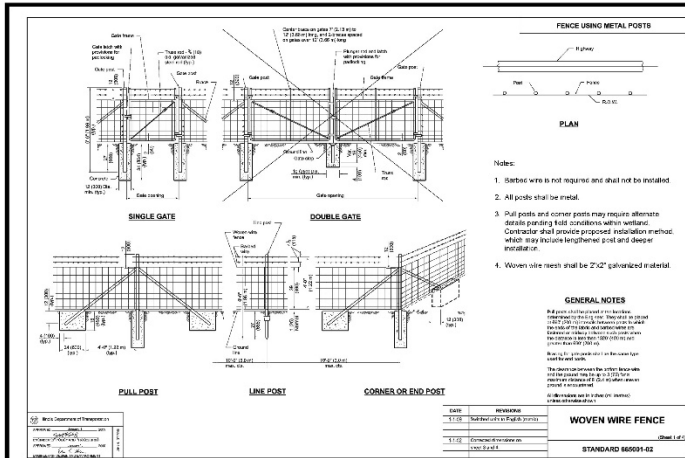

① **BID ALTERNATE 3 Plant Protection Fence**  
(Not to Scale)

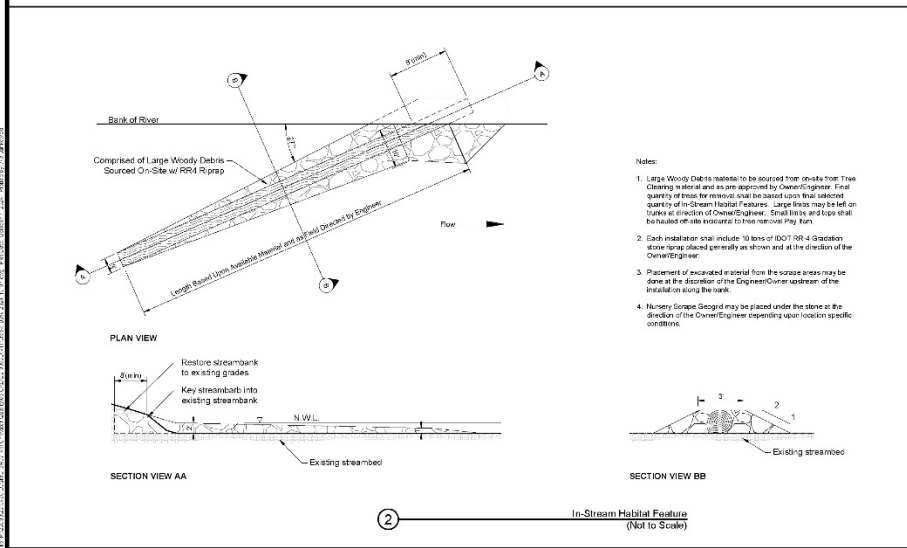

② **In-Stream Habitat Feature**  
(Not to Scale)

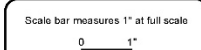

**LEGEND**

No.	Revision/Issue	Date

**Hey and Associates, Inc.**  
Engineering, Ecology and Landscape Architecture  
36375 West Commerce Drive, Suite 601  
Volo, Illinois 60073  
Office: (847) 740-0888  
Fax: (847) 740-2888  
Volo@HEYASOC.COM  
PROFESSIONAL DESIGN FIRM  
LICENSE NO. 194-000269

**Mill Creek Water Quality Enhancement**  
Lake County, IL

**Details**

PROJECT NO.	25-0430	SHEET NO.	C5.2
DRAWN BY	DAK	CHECKED BY	JAW
DATE OF DRAWING	10/27/2024	SCALE	AS SHOWN

Issued for Bid

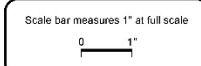
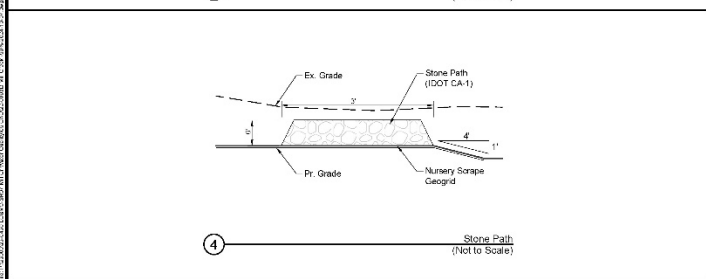
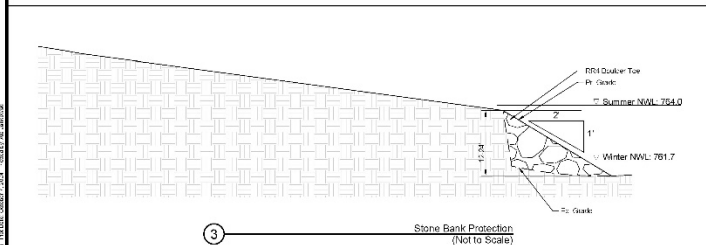
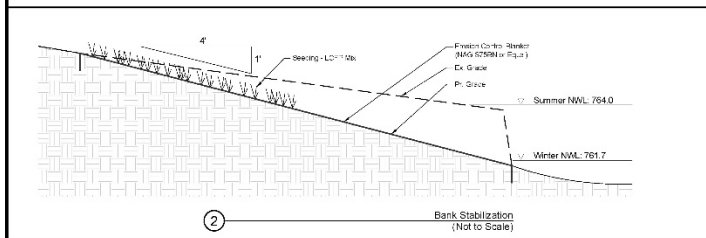
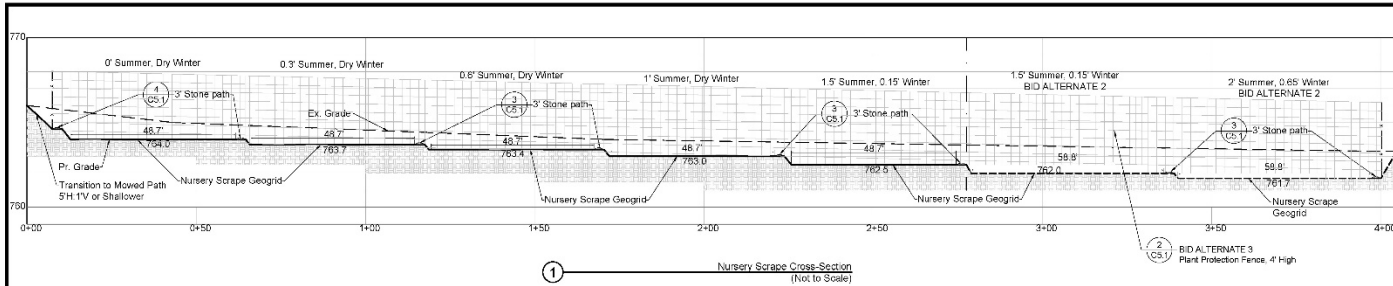

**LEGEND**

- Project Boundary
- Parcel Boundary
- FEMA Floodplain by Elevation
- FEMA Floodway
- Lake County Contours
- Surveyed Wetland Boundary
- Surveyed Waters Boundary
- Prop. Contours
- Prop. Construction/Nursery Access Edge
- Prop. Flow Diversion

No.	Revised/Issue	Date

**Hey and Associates, Inc.**  
 Engineering, Ecology and Landscape Architecture  
 26575 WISCONSIN CONCEPT DRIVE, SUITE 601  
 Volo, ILLINOIS 60073  
 OFFICE (847) 740-0888  
 FAX (847) 740-2888  
 Volo@HEYASSOC.COM  
 PROFESSIONAL DESIGN FIRM  
 License No. 184-002429

**Mill Creek Water Quality Enhancement**  
 Lake County, IL

**Details**

REVISION NO.	DESCRIPTION	DATE

DESIGNED BY	JAK	<b>C5.1</b>
DRAWN BY	AT_SEG	
CHECKED BY	JAK	
DATE PLOTTED	15/07/2024	11:07:12

Issued for Bid

COPYRIGHT © 2024 Hey and Associates, Inc.